

**APPLICATION REQUIREMENTS:**

Replacement of Electrical Box and/or its components for a Contactor-Relay Style Operator.



**DISCONNECT POWER AT THE FUSE BOX BEFORE PROCEEDING. IF NECESSARY REMOVE THE OPERATOR FROM ITS MOUNTED POSITION.**

**OPERATOR MUST BE PROPERLY GROUNDED AND CONNECTED IN ACCORDANCE WITH LOCAL ELECTRICAL CODES. NOTE: THE OPERATOR SHOULD BE ON A SEPARATE FUSED LINE OF ADEQUATE CAPACITY.**

**ALL ELECTRICAL CONNECTIONS MUST BE MADE BY A QUALIFIED INDIVIDUAL.**



**BEFORE BEGINNING, ENSURE REPLACEMENT ELECTRICAL BOX IS OF THE SAME POWER REQUIREMENTS AS EXISTING INCOMING POWER.**

**INSTALLATION INSTRUCTIONS**

**NOTE:** Refer to the Owner's Manual supplied with the operator for all mounting and wiring instructions. You will be required to reset limit nuts after installation.

**REMOVE EXISTING BOX:**

Remove the master link from the limit chain, remove the chain and place it aside. Disconnect the motor wires that pass into the electrical box.

Remove the four flanged hex screws securing the electrical box tabs to the motor frame and carefully remove the old box.

**MOUNTING NEW BOX:**

Ensure proper Right/Left handing of the Electrical Box Limit Sprocket.

Place the new electrical box on the motor frame, aligning the slotted tabs on the box with their corresponding holes on the motor frame (see illustration). Attach the new electrical box using the screws provided. Do not tighten screws at this time.

Replace the limit chain and secure with master link. Slide the new electrical box in its slots until most of the slack in the limit chain is picked up, being careful not to over-tighten chain. Secure the new electrical box to the motor frame by tightening the hex screws.

Reconnect the motor wires (as shown in the diagram inside electrical box cover or refer to Owners Manual) and replace the electrical box cover. Restoring power completes the installation.

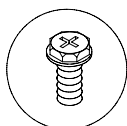
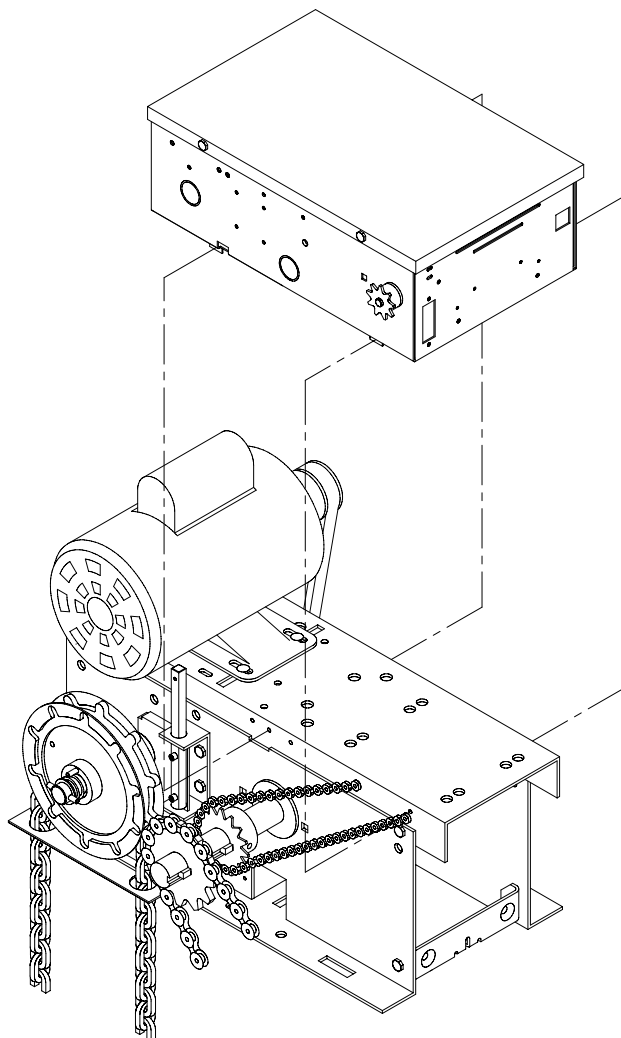

**NOTE:** ATTACH ELECTRICAL BOX TABS TO OUTSIDE OF MOTOR FRAME WITH SCREWS PROVIDED.

**WARNING**

Always Disconnect Power Whenever Installing or Servicing the Door Operator.

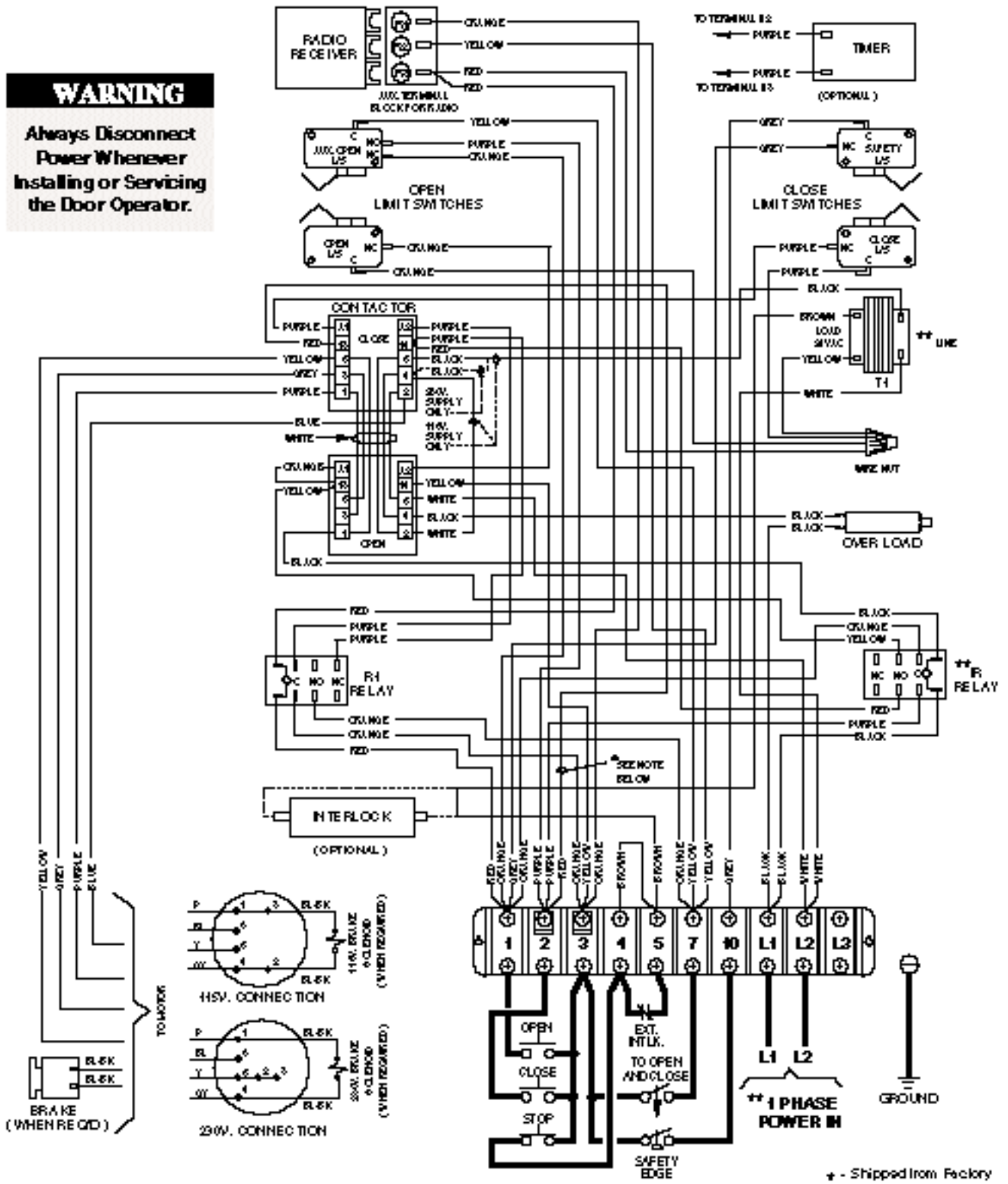

\*\* - Transformer Primary & Relay Voltages same as Line Volts.

TO REVERSE MOTOR DIRECTION INTERCHANGE PURPLE & GRAY WIRES.

**CLOSE CONTROL WIRING OPTIONS**

- \*C2 WIRING - Constant Pressure to Close  
RED WIRE ON TERMINAL #2 (Shipped from Factory)
- E2 WIRING - Momentary Contact to Close  
MOVE RED WIRE FROM TERMINAL #2 TO TERMINAL #3

**WARNING**  
Always Disconnect Power Whenever Installing or Servicing the Door Operator.

